



▲ D3-3L



▲ D3-4L



▲ D3-3SL

◆ D3 捲門機特性表

型號	D3-3L	D3-4L	D3-3SL
淨重/毛重	10.57/11.3(kg)	10.61/11.34(kg)	10.56/11.29(kg)
荷重 kg	300kg(4 吋門軸)		
輸出轉速	39-40rpm(60Hz)		
馬達轉矩	110V(11.1kg-cm)/220V(12.3kg-cm)		
減速比	43.36		
額定時間	10min		
極數	4P		
功率	180W		
滿載電流	110V(4.65A)/220V(1.8A)		
電容器	110V-30uF/220V-14uF		
手拉鏈條	2.5M		
主動輪	50×9T		
架板輪	50×50T		

◆ D3 尺寸圖/腳座尺寸(mm)

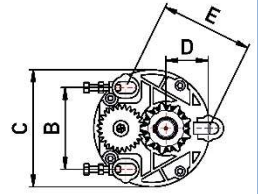
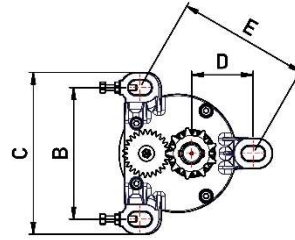
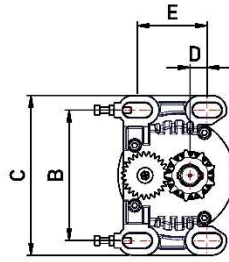
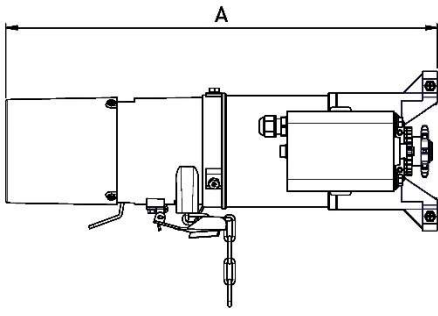

	A	B	C	D	E
D3-3L/3R	446	134	166	63.4	134
D3-4L/4R/4T	446	134	164	17.5	72
D3-3HL/3HR/3HT	446	84	120	43.7	95

◆捲門機系列-D3 腳座選擇

	<p>三腳鏈條式:D3-3L 傳動鏈輪:50×9T</p>	<p>選配: 40×10T 50×10T 60×8T</p>
	<p>三腳插心式:D3-3R</p>	<p>50×9T(在架板不附)</p>
	<p>四腳鏈條式:D3-4L 傳動鏈輪:50×9T</p>	<p>選配: 40×10T 50×10T 60×8T</p>
	<p>四腳插心式:D3-4R</p>	<p>50×9T(在架板不附)</p>
	<p>四腳齒輪式:D3-4T 傳動齒輪:M5×9T</p>	<p>選配: M5×8T M5×12T- M5×9T- M6×8T M5×10T- M6×9T-</p>
	<p>隱藏鏈條式:D3-3HL 傳動鏈輪:50×9T</p>	<p>選配: 40×10T 50×10T 60×8T</p>
	<p>隱藏插心式:D3-3HR</p>	<p>50×9T(在架板不附)</p>
	<p>隱藏齒輪式:D3-3HT 傳動齒輪:M5×10T-</p>	<p>選配: M5×8T M5×9T M5×9T-</p>